



Jeakue
佳奎

FB25/30

2.5/3.0 ton Li-ion Counterbalance Forklift Truck

L-ION
TECHNOLOGY

- PMSM technology for better efficiency and performance
- Removable Li-ion battery fitting multi-shift operation better
- All-rounder both for indoor and outdoor usage
- Ergonomic zone for fatigue-free work

Shenchuan(Shanghai)Heavy Industrial Machinery Co.,Ltd
www.jeakue.com

FEATURE

■ PMSM technology for better efficiency and performance

The FB25/30 adopts permanent magnet synchronous motor (PMSM) technology to deliver longer battery life. This efficiency optimization motor brings better energy savings and maximizes the battery uptime at optimal working scenarios by 10% comparing to regular motors.



PMSM



Longer
uptime



Energy
saving



■ Removable Li-ion battery offering convenience for daily usage

The FB25/30 is designed around the advantages of lithium technology, equipped with removable 80V/150Ah Li-ion battery as standard. It allows for not only opportunity charging and zero maintenance, but also being laterally pulled and replaced easily, which makes it a helper for rugged environments that lack of charging facilities.



■ All-rounder for both indoor and outdoor usage

The compact FB series features a small turning radius, 2217mm of FB25 and 2250mm of FB30, and its agility ensures handling capacities in tight spaces and narrow aisles. Besides, the FB25/30 is water-protected and can be operated outdoors, even in the rain.

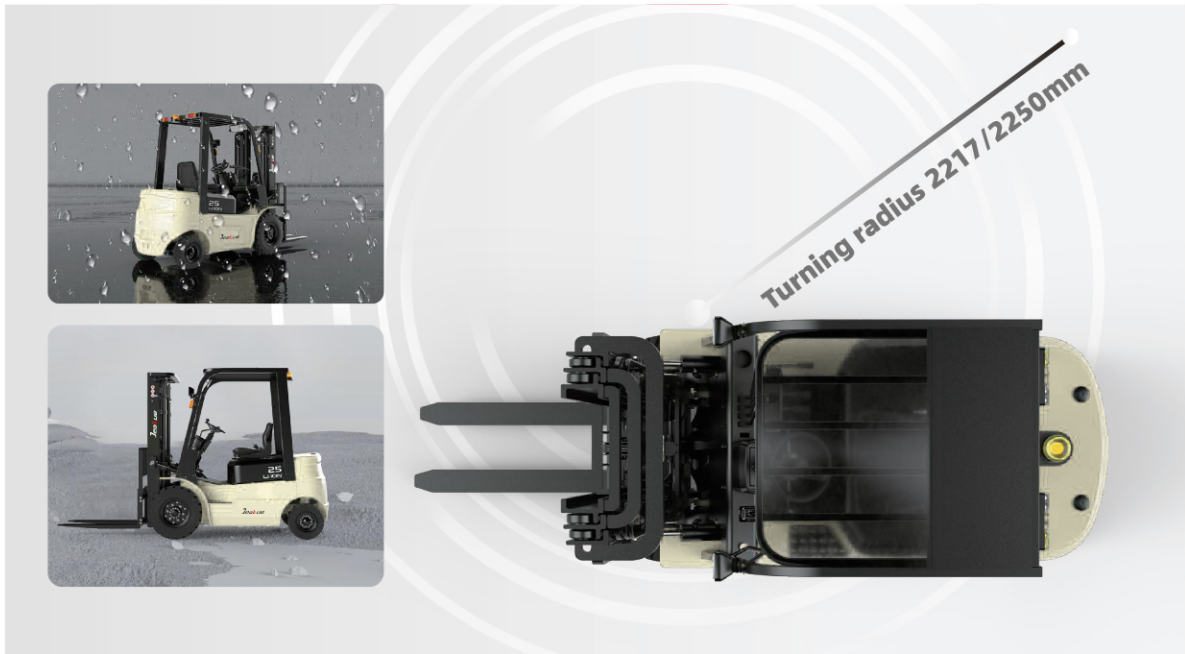

■ Ergonomic zone for fatigue-free work

The FB25/30 comes offers a spacious work space, with a simplified panel, and just a steering wheel and a comfortable pedal. All are designed in line with ergonomic considerations for operation comfort.

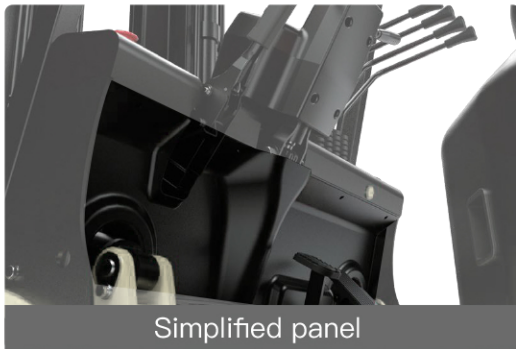

2.5/3.0 ton Li-ion Counterbalance Forklift Truck

FB25/30

Distinguishing mark	1.1	Manufacturer			JEAKUE	JEAKUE
	1.2	Model designation			FB25	FB30
	1.3	Drive unit			Electric	Electric
	1.4	Operator type			Seated	Seated
	1.5	rated capacity	Q	kg	2500	3000
	1.6	Load center distance	c	mm	500	500
	1.8	Load distance, centre of drive axle to fork	x	mm	481	481
	1.9	Wheelbase	y	mm	1650	1650
	Service weight	2.1	Service weight		kg	3920
2.2		Axle loading, laden front/rear		kg	5690/730	6500/625
2.3		Axle loading, unladen front/rear		kg	1700/2220	1715/2410
Tyres/chassis	3.1	Tyre type			Pneumatic	Pneumatic
	3.2	Tyre size, front		mm	7.00-12-16PR	7.00-12-16PR
	3.3	Tyre size, rear		mm	18X7-8-14PR	18X7-8-14PR
	3.5	Wheels, number front/rear (x=drive wheels)		mm	2x/ 2	2x/ 2
	3.6	Tread, front	b10	mm	975	975
	3.7	Tread, rear	b11	mm	955	955
	Dimensions	4.1	Tilt of mast/fork carriage forward/backward	α/β	°	6/ 10
4.2		Height, mast lowered	h1	mm	2070	2070
4.3		Free lift	h2	mm	135	135
4.4		Lift height	h3	mm	3000	3000
4.5		Height, mast extended	h4	mm	4110	4110
4.7		Height of overhead/ guard cabin	h6	mm	2170	2170
4.8		Seat height/standing height	h7	mm	1110	1110
4.12		Tow coupling height	h10	mm	295	295
4.19		Overall length	l1	mm	3566	3606
4.20		Length to face of forks	l2	mm	2496	2536
4.21		Overall width	b1/b2	mm	1154	1154
4.22		Fork dimensions	s/e/l	mm	45×122×1070	50×122×1070
4.23		A,B Fork carriage class/type A, B			3A	3A
4.24		Fork carriage width	b3	mm	1040	1040
4.31		Ground clearance, laden, below mast	m1	mm	120	120
4.32		Ground clearance, center of wheelbase	m2	mm	150	150
4.34.1		Aisle width for pallets 1000×1200 crossways	Ast	mm	3898	3931
4.34.2		Aisle width for pallets 800×1200 crossways	Ast	mm	4098	4131
4.35		turning radius	Wa	mm	2217	2250
Performance data		5.1	Travel speed, laden/unladen		km/ h	11/12
	5.2	Lifting speed, laden/unladen		m/s	0.29/0.36	0.28/0.36
	5.3	Lowering speed, laden/unladen		m/s	0.4/0.43	0.4/0.43
	5.5	Drawbar pull, laden/unladen		N	—	—
	5.6	Max. drawbar pull, laden/unladen		N	—	—
	5.8	Max. gradeability, laden/unladen		%	15/15	15/15
	5.10	Service brake			Hydraulic	Hydraulic
	5.11	Parking brake			Mechanical	Mechanical
Electric-engine	6.1	Drive motor rating S2 60 min		kW	8	8
	6.2	Lift motor rating at S3 15%		kW	16	16
	6.4	Battery voltage/nominal capacity		V/Ah	80V150AH	80V150AH
	6.5	Battery weight		kg	—	—
	Addition data	8.1	Type of drive unit			AC
10.5		Steering design			Hydraulic	Hydraulic
10.7		ound pressure level at the driver's ear		dB(A)	< 74	< 74

If there are improvements of technical parameters or configurations, no further notice will be given.
The diagram shown may contain non-standard configurations.

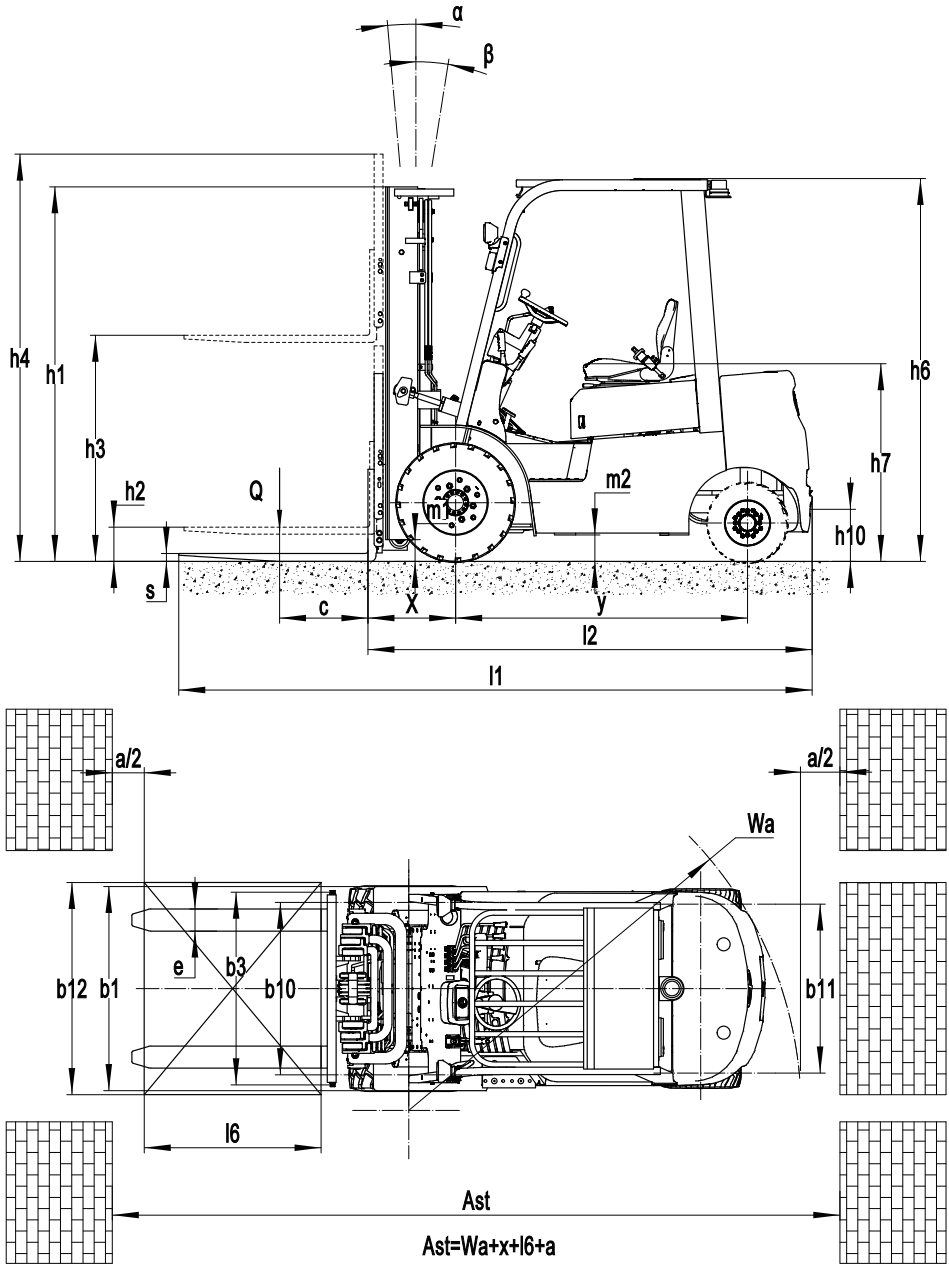

FB25 RATED CAPACITIES AND LOAD CENTERS GRAPH

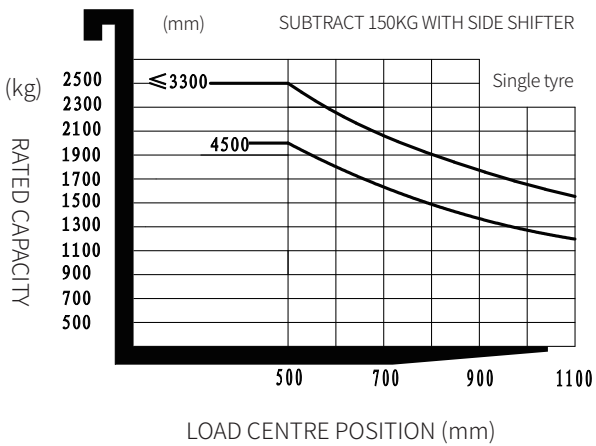

FB30 RATED CAPACITIES AND LOAD CENTERS GRAPH

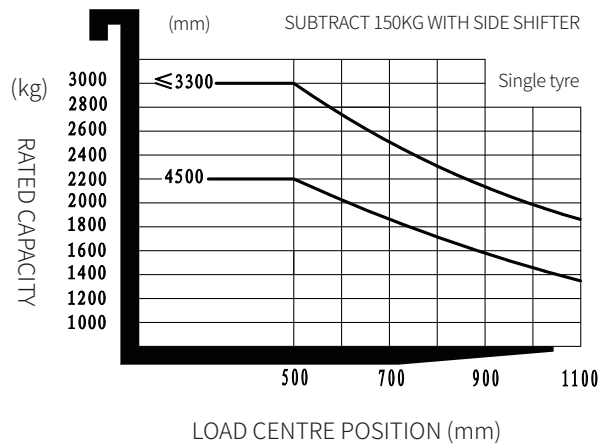

Mast Option

Mast types	Lift height (h3)	Height, Mast			Height, Free lift(h2)	
		Height, mast lowered(h1)	Height, mast extended(h4)		No shelving	With shelving
	No shelving		With shelving	mm		
2-Standard Mast	3000	2060	3630	4095	120	120
	3300	2210	3930	4395	120	120
3-Free Mast	4500	2120	5130	5595	1490	1025

Option

No.	Optional items	FB25/30
1.1	Fork dimension	<ul style="list-style-type: none"> ○122*45*1070○122*45*1150○122*45*1220○122*45*1370 ○122*45*1520○122*45*1600○122*45*1700○122*45*1820 ○122*45*2000○122*45*2200○122*45*2400
1.4	Fork carriage width	●1040mm○Yes and can be customized
1.5	Fork carriage height	●1095mm○Yes and can be customized
2.5	Front wheel material	●Pneumatic○solid○Non-marking
2.6	Rear wheel material	●Pneumatic○solid○Non-marking
2.7	Battery capacity	●80V150AH
2.8	Charger	○80V35A external○80V65A external●80V35A integrated○80V60A integrated
2.9	Battery indicator	●With time
2.10	Seat type	○Rugular○Premiu○Suspension○Suspension + seatbelt logic switch
2.11	Attachments	●No○Built-in sideshifter○External shifter○Fork positioner
2.13	Traction pin	●Yes
2.14	Electrostatic chain	●Yes
3.5	Front lamp	●LED
3.6	Rear lamp	●No○LED
3.7	Warning lamp	●Yes
3.8	Steering lamp	●Yes
3.9	Blue lamp	●No○2 front○1 rear○2 front + 1 rear
3.10	Area warning lamp	●No○1 left + 1 right
3.11	Rearview mirror	●1 rearview mirror○Add rearview mirror on both sides
3.12	Buzzer	●Yes
3.17	OPS system	●No○Yes and not customized
3.23	Telematics	●No○Yes and not customized
4.1	Battery side pull function	●Yes and not customized
5.1	Battery side pull attachment	●No○Yes and not customized

Note: ●Standard ○ Optional - Inconformity